

GETTING ACQUAINTED WITH YOUR INSTRUMENT

THE TROMBONE

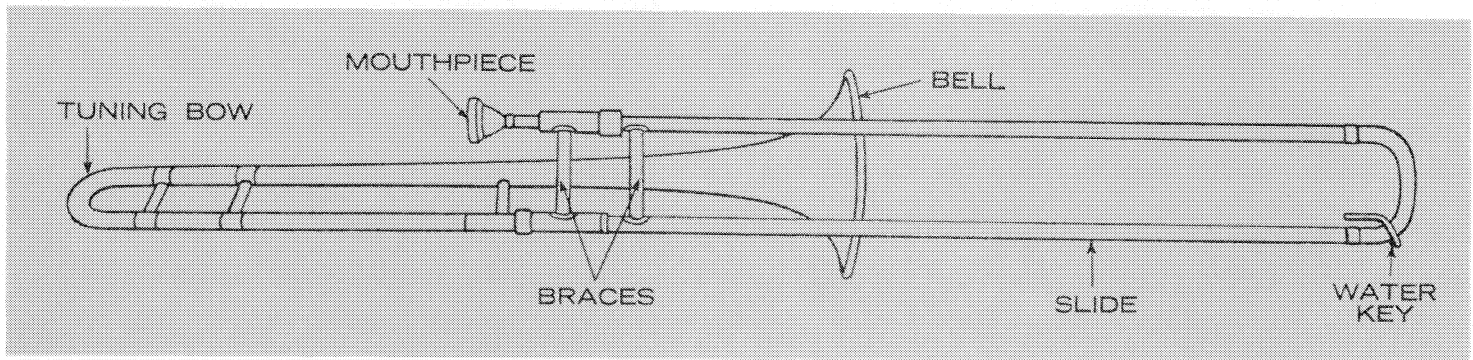

Left Hand

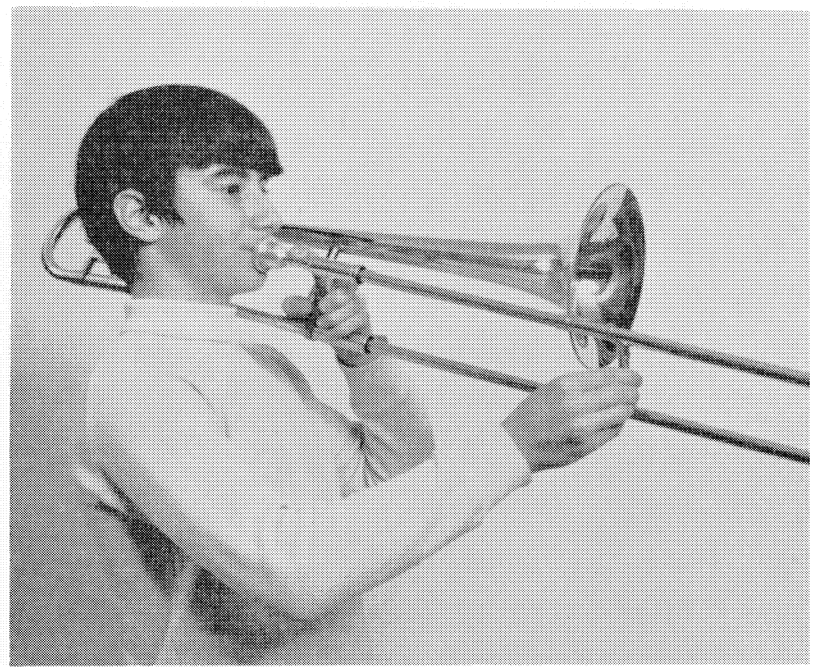

Right Hand

Your teacher will show you how to put your instrument together.

LEFT HAND: Keep your left thumb in back of the bell brace. Let your left index finger rest on the top of the mouthpiece tube. The other fingers are placed around the first slide brace. The wrist should be kept as straight as possible.

RIGHT HAND: The thumb and the first two fingers are used to grasp the slide. Make sure that the slide lock is secure when the slide is not held.

GETTING READY TO PLAY



NO. 1

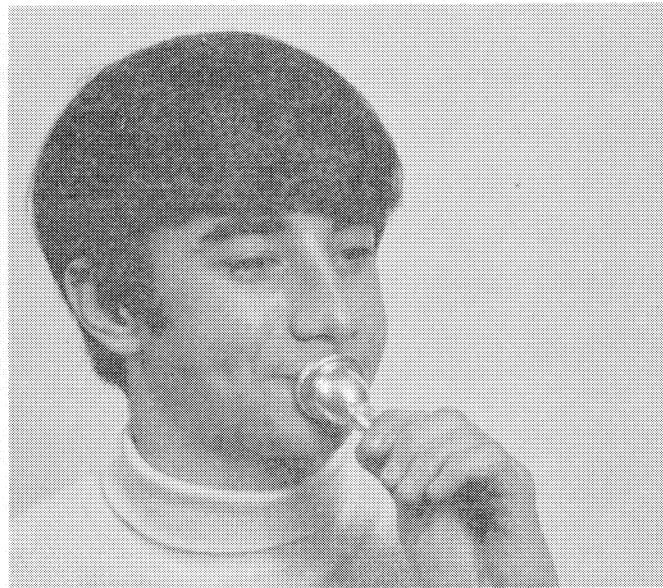

NO. 2



NO. 3



NO. 4

1. Look at the photographs on page 4. Form your lips as shown in photo No. 1. Keep your lips stretched firmly against your teeth. Take a large breath at the corners of your mouth. *Do not raise your chest or shoulders.* Push the air out between your lips. Try to produce a BUZZING sound. This BUZZ is a vibration that will cause the instrument to play.
2. When you have succeeded in making the BUZZ, place the mouthpiece on your lips as shown in photo No. 2. Your teacher will help you place it approximately 1/3 on the upper lip and 2/3 on the bottom. Take a breath as before. Make sure your breath is deep. Try to BUZZ through the mouthpiece. Listen for a sound that is like a QUACK.